

Ceramic Resonators (CERALOCK®)



Lead Type Two-Terminals CSBLA Series

"CERALOCK" with two leaded terminals.

The CSBLA series ceramic resonator owe their development to MURATA's innovative expert technologies and the application of mass production techniques typically utilized in the manufacture of piezoelectric ceramic components. Because of their high mechanical Q and consistent high quality, the CSBLA series are ideally suited to microprocessor and remote control unit applications.

■ Features

1. The series is stable over a wide temperature range and with respect to long-term aging.
2. The series comprises fixed, tuned, solid-state devices.
3. The resonators are miniature and light weight.
4. They exhibit excellent shock resistance performance.
5. Oscillating circuits requiring no adjustment can be designed by utilizing these resonators in conjunction with transistors or appropriate ICs.

■ Applications

- Square-wave and sine-wave oscillator.
- Clock generator for microprocessors.
- Remote control systems.



CSBLA_E
375-429kHz

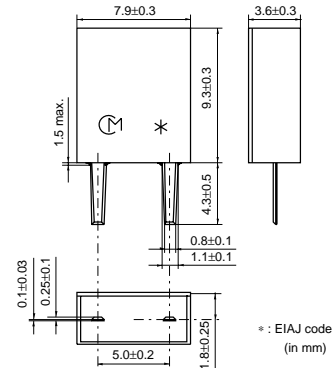

CSBLA_E
430-509kHz

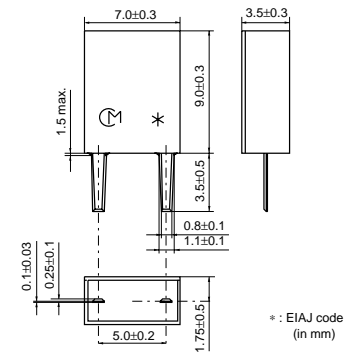

CSBLA_E
510-699kHz

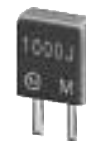
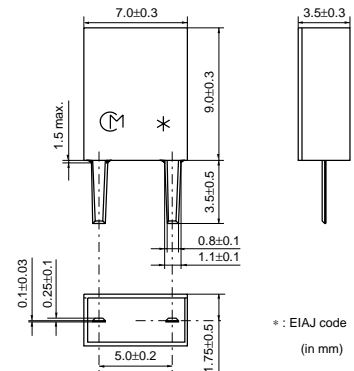

CSBLA_J
700-1250kHz

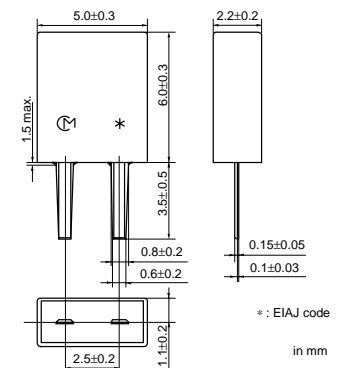

Part Number	Oscillating Frequency (kHz)	Initial Tolerance	Temp.Stability (%)	Temperature Range (°C)	Aging (10 years) (%)	Use
CSBLA_E	375 to 699	±2kHz	±0.3	-20 to 80	±0.3	-
CSBLA_J	700 to 1250	±0.5%	±0.3	-20 to 80	±0.3	-

Irregular or stop oscillation may occur under unmatched circuit conditions. Please check the actual conditions prior to use.
The order quantity should be an integral multiple of the "Minimum Quantity" shown in the packaging page.

■ Oscillation Frequency Measuring Circuit

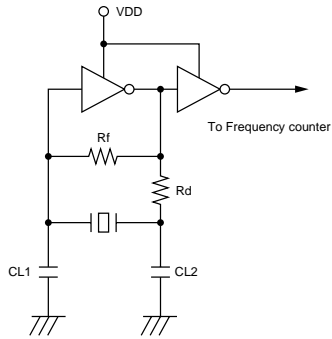

■ Oscillation Frequency Temperature Stability

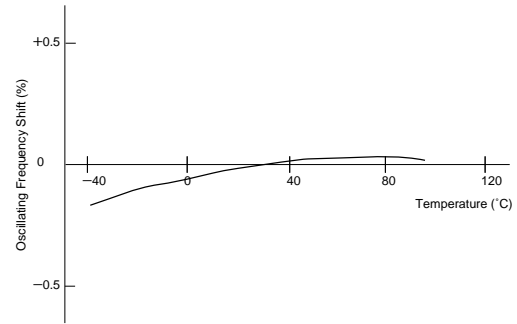

kHz Lead Type Notice

■ Notice (Soldering and Mounting)

CSBLA_E

The component cannot be withstand washing.

■ Notice (Soldering and Mounting)

CSBLA_J

(1) Cleaning Solvent

HCFC, Isopropanol, Tap water, Demineralized water,
Cleanthrough750H, Pine alpha 100S, Techno care
FRW.

(2) Temperature Difference:dT *1

$dT \leq 30$ C. (dT=Component-solvent)

*1 ex. In case the component at +90 C. immerses
into cleaning solvent at +60 C., then
 $dT=30$ C.

(3) Condition

1. Ultrasonic Wash

1 minute max. in above solvent at +60 C. max.

(Frequency:28kHz, Output:20W/L)

2. Immersion Wash

5 minutes max. in above solvent at +60 C. max.

3. Shower or Rinse Wash

5 minutes max. in above solvent at +60 C. max.

(4) Drying

5 minutes max. by air blow at +80 C. max.

(5) Others

1. Total washing time should be within 10 minutes.

2. Please insure the component is thoroughly
evaluated in your application circuit.

3. The component may be damaged if it is washed
with alkali cleaning solvent.

kHz Type Notice

■ Notice (Storage and Operating Condition)

CSBFB_J

Please do not apply excess mechanical stress to the component and lead terminals at soldering.

Conformal coating of the component is acceptable.

However, the resin material, curing temperature, and other process conditions should be evaluated to confirm stable electrical characteristics are maintained.

Ultrasonic cleaning of the component is acceptable.

However, the size of bath, size and thickness of PBC should be evaluated to confirm stable electrical characteristics are maintained.

In case of the bulk component, dry heating treatment (130 C. for 5 hours min.) is required before reflow soldering. Then, the component should be soldering within 48 hours after dry heating treatment.

■ Notice (Storage and Operating Condition)

CSBLA_E

Please do not apply excess mechanical stress to the component and lead terminals at soldering.

Conformal coating or washing to the component is not acceptable. Because it is not hermetically sealed.

■ Notice (Storage and Operating Condition)

CSBLA_J

Please do not apply excess mechanical stress to the component and lead terminals at soldering.

Conformal coating of the component is acceptable.

However, the resin material, curing temperature, and other process conditions should be evaluated to confirm stable electrical characteristics are maintained.

Ultrasonic cleaning of the component is acceptable.

However, the size of bath, size and thickness of PBC should be evaluated to confirm stable electrical characteristics are maintained.

■ Notice (Rating)

The component may be damaged if excess mechanical stress is applied.

■ Notice (Handling)

"CERALOCK" may stop oscillating or oscillate irregularly under improper circuit conditions.